

INSTRUCTION MANUAL

ELECTRIC CHAMFERING TOOL

Please read this manual carefully before you attempt to use your tool so that you may use it properly and safely.

MINI BEVELER Model EMB-0307C

PROFESSIONAL TOOL

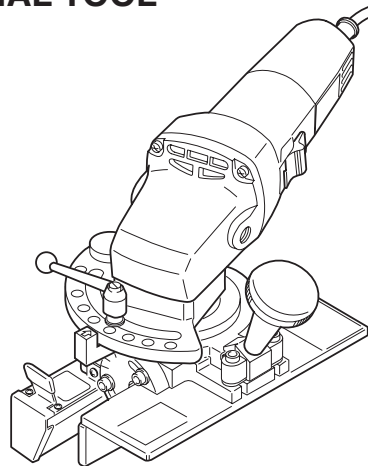

Specifications

Model		EMB-0307C	
Power Source(Single Phase)		115 V AC 50/60 Hz	230 V AC 50/60 Hz
Rated Power Consumption		900W	
Rated Duty Cycle		Continue	
Rated Speed(No Load)		13300 min ⁻¹	
Chamfering Capacity	Stainless Steel	Up to 3mm Chamfer or 2mm, 3mm, 4mm Radius	
	Mild Steel	Up to 7mm Chamfer or 2mm, 3mm, 4mm Radius	
Chamfering Angle		15-45 Degrees	
Mass(Weight)		3.9 kg	
Sound Pressure Level	No Load	88 dB(A)	
	Load	93 dB(A)	
Sound Power Level	No Load	99 dB(A)	
	Load	104 dB(A)	
Vibration Level	Load	Motor	8.1 m/s ²
		Knob	4.9 m/s ²

Due to continuous product development/improvement the specifications and configurations in this document are subject to change without prior notice.



Manufactured by :

NITTO KOHKI Co., Ltd.

9-4, NAKAIKIGAMI
2-CHOME, OHTA-KU,
TOKYO, 146-8555, JAPAN

Tel : +81-3-3755-1111

Fax : +81-3-3753-8791

Keep the manual handy – so you can use it whenever necessary.

Original Instructions

TQ14395-1 05/2017

Thank you very much for your purchase of this **Nitto Kohki product**.







Before using your tool, please read this manual carefully so that you may use it properly to get the most out of it.

Please keep the manual handy - so you can use it whenever necessary.

- **English** : Please ask your dealer or distributor for instruction manual in local language(s).
- **German** : Bitte fragen Sie Ihren Händler nach eine Betriebsanleitung in Landessprache.
- **French** : S'il vous plait, veuillez demandez á votre fournisseur de manuel instruction en langue locale.
- **Spanish** : Por favor, cantacte con su distribuidor para el manual de instrucciones en español.
- **Portuguese** : Por favor pessa ao seo agente ou distribuidor o manual de instrucces ih linguagen local.
- **Italian** : Per Manuale Istruzioni in lingua locale Vi preghiamo di rivolgervi al rivenditore o distributore.
- **Dutch** : Vraag uw handelaar om een nederladstalige gebruiksaanwijzing.
- **Swedish** : Be er lokala Åtreförsäljare eller distributör om manualer pá svenska.
- **Danish** : Venligst henvend Dem til den danske distributør for instructions manualer.
- **Polish** : Prosze pytac swojego dealera lub dystrybutora o instrukcje obslugi w jezyku localnym.
- **中文** : 請向當地供應商或經銷商詢問中文使用說明書



CONTENTS	page
IMPORTANT SAFETY INSTRUCTIONS	2
GENERAL POWER TOOL SAFETY WARNINGS	2
GENERAL TOOLS SAFETY WARNINGS	3
ADDITIONAL SAFETY	
WARNINGS FOR POWER TOOLS	4
INSTRUCTIONS FOR THIS TOOL	5
1. USAGE	5
2. CHECK THE CONTENTS OF THE PACKAGE	5
3. NAME OF PARTS	5
4. PREPARATIONS	5
5. HOW TO OPERATE THE TOOL	6
6. HOW TO REPLACE INDEXABLE INSERT	9
7. MAINTENANCE AND INSPECTION	9
8. CONDITION FOR USE	10
9. ORDERING SERVICE PARTS	10
10. OPTIONAL PARTS	10
11. EXPLODED DIAGRAM : EMB-0307C	11

PICTOGRAM

-  Warning: It might be dangerous to operate the tool if the instructions supplied are not followed.
-  Using this tool improperly could result in serious injury. Read the instruction manual before use.
-  Always wear suitable eye protection.
-  Always wear suitable hearing protection.
-  Always wear respiratory protective equipment (PPE).
-  Always wear protective gloves for protection of hands from vibration, Shock and Burns.

Storage Temperature : -10°C - 60°C (no freezing)
 Storage Humidity : Maximum 90% at 25°C (no dewing)
 Operating Temperature : 5°C - 40°C
 Operating Humidity : Maximum 90% at 25°C (no dewing)
 Altitude : 1000m Max.
 Over-voltage Category : Category II according to IEC60664-1
 Pollution Degree : Degree 3 according to IEC60664-1

The following Safety notations are used throughout the manual to highlight safety precautions for the user and for the tool.

 WARNING:	Indicates a potentially hazardous situation which, if not avoided by following the instructions given, could result in death or serious injury.
 CAUTION:	Indicates a potentially hazardous situation which, if not avoided by following the instructions given, could result in injury or material damage.

Please note, however, that failure to observe safety precautions under the “ **Caution**” category could result in a serious occurrence depending on the situation: please observe all safety precautions in the manual.

Caution: Important precautions for tool setup, operation and maintenance.

IMPORTANT SAFETY INSTRUCTIONS

When using the tool, please observe the safety precautions below to prevent possible accident or injury.

GENERAL POWER TOOL SAFETY WARNINGS

WARNING

Read all safety warnings and all instructions. Failure to follow the warnings and instructions may result in electric shock, fire and/or serious injury.

Save all warnings and instructions for future reference.

The term "power tool" in the warnings refers to your mains-operated (corded) power tool or battery-operated (cordless) power tool.

1) Work area safety

- a) **Keep work area clean and well lit.** Cluttered or dark areas invite accidents.
- b) **Do not operate power tools in explosive atmospheres, such as in the presence of flammable liquids, gases or dust.** Power tools create sparks which may ignite the dust or fumes.
- c) **Keep children and bystanders away while operating a power tool.** Distractions can cause you to lose control and have an accident or injury.

2) Electrical safety

- a) **Power tool plugs must match the outlet. Never modify the plug in any way. Do not use any adapter plugs with earthed (grounded) power tools.** Unmodified plugs and matching outlets will reduce risk of electric shock.
- b) **Avoid body contact with earthed or grounded surfaces, such as pipes, radiators, ranges and refrigerators.** There is an increased risk of electric shock if your body is earthed or grounded.
- c) **Do not expose power tools to rain or wet conditions.** Water entering a power tool will increase the risk of electric shock.
- d) **Do not abuse the cord. Never use the cord for carrying, pulling or unplugging the power tool. Keep cord away from heat, oil, sharp edges or moving parts.** Damaged or entangled cords increase the risk of electric shock.
- e) **When operating a power tool outdoors, use an extension cord suitable for outdoor use.** Use of a cord suitable for outdoor use reduces the risk of electric shock.

- f) **If operating a power tool in a damp location is unavoidable, use a residual current device (RCD) protected supply.** Use of an RCD reduces the risk of electric shock.

3) Personal safety

- a) **Stay alert, watch what you are doing and use common sense when operating a power tool. Do not use a power tool while you are tired or under the influence of drugs, alcohol or medication.** A moment of inattention while operating power tools may result in serious personal injury.
- b) **Use personal protective equipment. Always wear eye protection.** Protective equipment such as dust mask, non-skid safety shoes, hard hat, or hearing protection used for appropriate conditions will reduce personal injuries.
- c) **Prevent unintentional starting. Ensure the switch is in the off-position before connecting to power source and/or battery pack, picking up or carrying the tool.** Carrying power tools with your finger on the switch or energising power tools that have the switch on invites accidents.
- d) **Remove any adjusting key or wrench before turning the power tool on.** A wrench or a key left attached to a rotating part of the power tool may result in personal injury.
- e) **Do not overreach. Keep proper footing and balance at all times.** This enables better control of the power tool in unexpected situations.
- f) **Dress properly. Do not wear loose clothing or jewellery. Keep your hair, clothing and gloves away from moving parts.** Loose clothes, jewellery or long hair can be caught in moving parts and result in serious personal injury.
- g) **If devices are provided for the connection of dust extraction and collection facilities, ensure these are connected and properly used.** Use of dust collection can reduce dust-related hazards.

4) Power tool use and care

- a) **Do not force the power tool. Use the correct power tool for your application.** The correct power tool will do the job better and safer at the rate for which it was designed.
- b) **Do not use the power tool if the switch does not turn it on and off.** Any power tool that cannot be controlled with the switch is dangerous and must be repaired.
- c) **Disconnect the plug from the power source and/or the battery pack from the power tool**

before making any adjustments, changing accessories, or storing power tools. Such preventive safety measures reduce the risk of starting the power tool accidentally.

- d) **Store idle power tools out of the reach of children and do not allow persons unfamiliar with the power tool or these instructions to operate the power tool.** Power tools are dangerous in the hands of untrained users.
- e) **Maintain power tools. Check for misalignment or binding of moving parts, breakage of parts and any other condition that may affect the power tool's operation. If damaged, have the power tool repaired before use.** Many accidents are caused by poorly maintained power tools.
- f) **Keep cutting tools sharp and clean.** Properly maintained cutting tools with sharp cutting edges are less likely to bind and are easier to control.
- g) **Use the power tool, accessories and tool bits etc. in accordance with these instructions, taking into account the working conditions and the work to be performed.** Use of the power tool for operations different from those intended could result in a hazardous situation.

5) Service

- a) **Have your power tool serviced by a qualified repair person using only identical replacement parts.** This will ensure that the safety of the power tool is maintained.

GENERAL TOOLS SAFETY WARNINGS

WARNING

TO OPERATORS

- **Always wear suitable eye protection.**
Remember, regular glasses are not safety glasses. The lenses are only shock resistant, which will not give you sufficient eye protection you may need in your working environment.
- **Always wear suitable hearing protection.**
- **Wear respiratory protective equipment (PPE).**
Wear respiratory protective equipment (PPE) when working in an environment where dust particles are generated in operation.
- **Always wear protective gloves for protection of hands from vibration, shock and burns.**
- **Never touch any moving parts of the tool when running.**

BEFORE OPERATION

- **Inspect tool before use.**

Before using, check that screws are securely tightened, that any protective cover or guard is securely in place, other parts are free from damage and that the tool runs as it should.

Check that moving parts are properly adjusted for positioning and tightened, that parts are free from damage and properly mounted, and that all other parts are in good condition for normal operation.

Should you find any damage to the protective cover or other part, replace it in accordance with the Operation Manual. If there are no instructions in the Manual, please contact the sales agent through which you have purchased your tool or an authorized dealer near you for repair.

Likewise, if a switch failure occurs, contact sales agent through which you have purchased your tool or an authorized dealer near you for repair.

Do not use the tool if it does not start or stop with the start/stop switch.

- **Securely mount cutter.**

An improperly mounted cutter may fly out, causing possible damage to the tool or injury to the operator.

- **Use a tool appropriate for the application.**

Avoid heavy-duty application that is beyond the capacity of tool.

- **Do not use the tool for purposes other than what it is designed for.**

- **Do not abuse tool.**

Use tool in accordance with the specifications: you'll get the most out of it while ensuring safety.

- **Securely fasten workpiece in place.**

Use a vice or clamp to securely fasten the workpiece in place. It is much safer this way than holding it in your hand, allowing you to operate the tool with both hands.

ABOUT HANDLING

- **How to store tool.**

When the tool is not used, store it in a dry area and out of reach of children.

- **How to carry tool.**

Do not touch the start switch while the tool is being carried.

- **Do not leave the tool unattended while it is running.**

Turn off the start switch and disconnect the tool from power source. Do not leave the work area until the tool comes to a complete stop.

MAINTENANCE/SERVICE

- **Do not take apart or modify tool.**

Disassembly or modification carried out without the supervision of a qualified or authorized service engineer could result in an accident or injury.

- **Inspect cutting tool and accessories, etc.**

Always check to see that cutting tool and accessories, etc. are in good operating condition without damage or deterioration before you mount them on the tool. Should you find any damage to an accessory or part, please contact sales agent through which you have purchased your tool or an authorized dealer near you for repair.

- **Check parts for damage.**

When you have found damage to accessory or other part, carefully check the damaged part to determine the extent of influence it has upon the functions of the tool – that is, determine whether it can still perform its normal functions.

Check to see that the linkage of the moving parts is OK, that all parts are OK without damage, that they are properly mounted, and that the tool functions normally. Should you find any damage to an accessory or part that may hamper proper functioning of the tool, please contact sales agent through which you have purchased your tool or an authorized dealer near you for repair.

- **Have your tool repaired at an authorized Nitto Service Center.**

For repair or parts replacement, please contact the sales agent through which you have purchased your tool or an authorized dealer near you.

- **Use only Nitto genuine parts.**

Use of improper parts may result in serious accident. To obtain a Nitto genuine part, consult this Manual or contact the sales agent from which you have purchased your tool directly.

- **Do not detach label or nameplate from tool.**

When a label/nameplate gets damaged, worn or becomes missing, contact the sales agent through which you have purchased your tool or Nitto Kohki Co. Ltd, directly for a replacement.

DISPOSAL

- When a tool is taken permanently out of service, it is advised that the tool is disassembled, degreased and parts separated by material and recycled locally in the appropriate manner.

ADDITIONAL SAFETY WARNINGS FOR POWER TOOLS

WARNING

- **Always use power source per specifications on the nameplate.**
- **Never connect the earthing conductor to a gas Pipe: if you do so explosion may result.**
- **Check to see that there is no abnormality in earth- clipping or earthing conductor.**

Conduct continuity check between the earth clip and a metal portion of the machine with a tester or insulation resistance tester, if you have one. Wiring connections involving the installation of earth bar or plate into the ground will call for the expertise of a qualified electrician. Please contact your local electrical contractor.
- **Before using the tool, ensure that ground-fault circuit interrupter for electrical shock guard is installed in the power source to which the tool will be connected, as required by the Ordinance on Labor Safety and Hygiene and/or the Technical Standard for Electrical Installation.**
- **Avoid abrupt, unintentional start.**

Before connecting a power supply plug to power source, make sure that the switch is turned off.
- **Do not replace the supply cord.**

When replacing the supply cord, please contact the sales agent through which you have purchased your tool or an authorized dealer near you.

INSTRUCTIONS FOR THIS TOOL

About Your Tool

WARNING

- Use of power is limited to the power source specified by the rating plate.
- Operate under the power source the voltage fluctuating rate of which is within $\pm 10\%$ of the rated voltage, and the frequency of which is 50/60Hz of sinusoidal wave.
- Before using the tool, make sure the power source to which it will be connected is fitted with an earth leakage breaker to prevent electric shock.
- Extension cord should be selected after ensuring the diameter is compatible with the length of the extension.

Beware of extremely long power cord (particularly wound up thin cords) as they may cause drops in voltage which weaken the magnetism, adversely affecting the performance and function of the unit. Do not share the extension cord with any other electric machine tools.

Extension Cord	
Max. Length	Nominal cross-sectional area
10 m	1.25 mm ² or more
15 m	2.00 mm ² or more
30 m	3.50 mm ² or more

- When performing maintenance, inspection, replacement or adjustment of parts, make sure to disconnect the attachment plug from the receptacle.
- To replace the Indexable Insert after using, do not touch with bare hands as the Indexable Insert and holder are heated at high temperature.
- Use our original Indexable Inserts.
- Do not use the worn or damaged Indexable Insert.
- If the unit is exposed under sub-zero temperature for a prolonged period of time, it may take some time to start up. This does not mean that the unit is broken. Once the unit has warmed up, it can be used again.

1. USAGE

This tool is for chamfering workpieces with a Indexable Insert.

2. CHECK THE CONTENTS OF THE PACKAGE

Check the contents and make sure that the tool does not have any damage which may have occurred during transportation. The contents should correspond to the list as follows. In case of damage/missing parts, please contact the sales agent from whom you purchased the tool.

Package Contents	Qty	Check
MINI BEVELER EMB-0307C	1set	
Dust Box Ass'y	1set	
Pan Head Screw 5×10	3	
Carbon Brush Ass'y	1set	
Hex. Socket Screw Key 4	1	
Indexable Insert with hole 12.7	1	
Indexable Insert Set Screw 4×7	1	
Hex. Nut M8	2	
Hex. Socket Set Screw 8×25 Special	2	
Spanner T-15D	1	
Instruction Manual	1	
Declaration of Conformity	1	

3. NAME OF PARTS

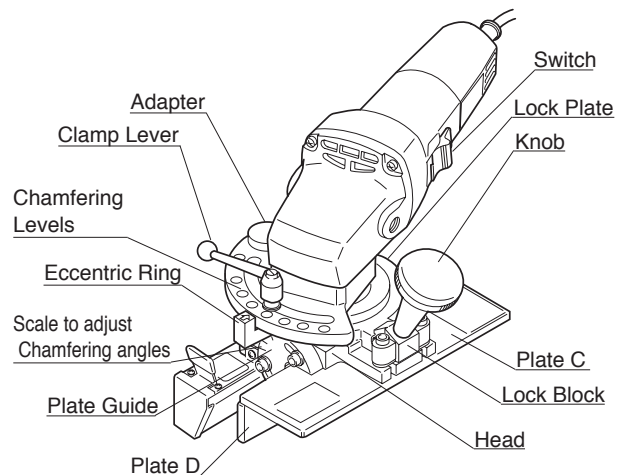

Fig.1

4. PREPARATIONS

WARNING

- Be Sure to turn the switch OFF and remove the power plug from power supply whenever setting up the tool.

4-1. Attaching the Dust Box

While pulling up the Dust Catcher in the arrow direction as illustrated, tighten 3 pcs. of Pan Head Screw 5×10 the Dust Box on the Head. (Fig.2)

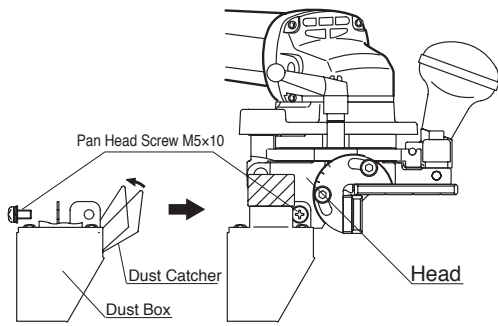

Fig.2

5. HOW TO OPERATE THE TOOL

! WARNING

- Always wear suitable eye protection, suitable hearing protection, protective gloves, and respiratory protective equipment.

5-1. Start and Stop

! CAUTION

- Always be sure the unit is in the OFF position before plugging the power cord into an outlet. To start, slide the switch forward while pushing down it. (Fig.3)
- To stop, slide back the switch. (Fig.3)

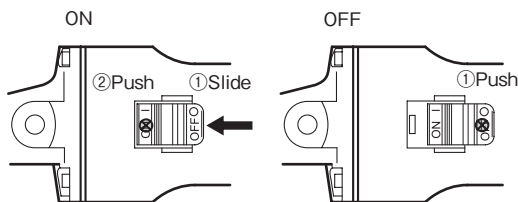

Fig.3

5-2. How to Adjust Chamfering Levels

! WARNING

- Be sure to turn the switch OFF and remove the power plug from power supply whenever adjusting chamfering levels.
- The max. chamfering capacity
Stainless Steel: Up to 3mm Chamfer
Mild Steel: Up to 7mm Chamfer

- (1) Loosen the Clamp Lever. (Fig.4)
- (2) Rotate the arrow mark of the Eccentric Ring to the Scale to adjust chamfering levels for chamfering amount required. (Fig.4)
- (3) Tighten the Clamp Lever after the adjustment. (Fig.4)

The level guide is only for reference. If accurate chamfering is required, set the tool at a chamfering

level about 0.5 smaller than the desired one. Try a test cut. Then adjust the tool for accurate chamfering.

In the case of Mild Steel

You can select chamfering levels from 0mm to 7mm Chamfer freely. The maximum chamfering capacity for one-cut is 4mm Chamfer. For 4mm Chamfer to 7mm Chamfer, chamfer a workpiece twice or three times.

(Ex. 7mm Chamfer : 4mm Chamfer → 5.5mm Chamfer → 7mm Chamfer Total 3 times)

In the case of Stainless Steel

You can select chamfering levels from 0mm to 3mm Chamfer freely. Chamfer the desired volume at a time without dividing the chamfering job to several times.

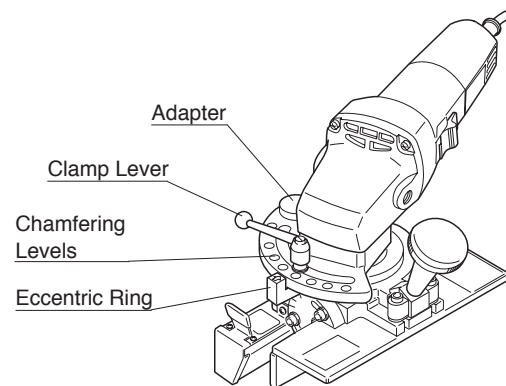

Fig.4

5-3. Adjustment of Radius Chamfering in Amount

- (1) Fix a radius chamfering Indexable Inserts.
- (2) Loosen the Clamp Lever. (Fig.4)
- (3) Rotate the arrow mark of the Eccentric Ring to the scale of the Adapter to adjust chamfering levels according to the size of the radius chamfering Indexable Inserts.
- (4) Tighten the Clamp Lever after the adjustment.
- (5) Conduct a test cutting. Readjust the Clamp Lever, so that sizes A and B become identical. (Fig.5)

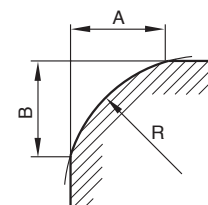

Fig.5

5-4. How To Adjust Chamfering Angle

! WARNING

- Be sure to turn the switch OFF and remove

the power plug from power supply whenever adjusting chamfering angle.

- (1) Loosen the Hex. Socket Head Cap Screws ① (4pcs) on both ends on the Plate Guide ② of Head ③ . (Fig.6)
- (2) Move the Plate Guide ② so that the scale of desired angle can align to the Guide Mark ④ .
- (3) Tighten the Hex. Socket Head Cap Screws ① .

The tool has the limit of chamfering width which depends on a chamfering angle. (Fig.7, Table.1)

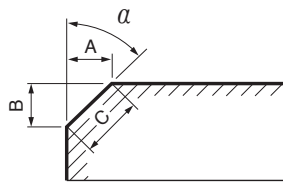
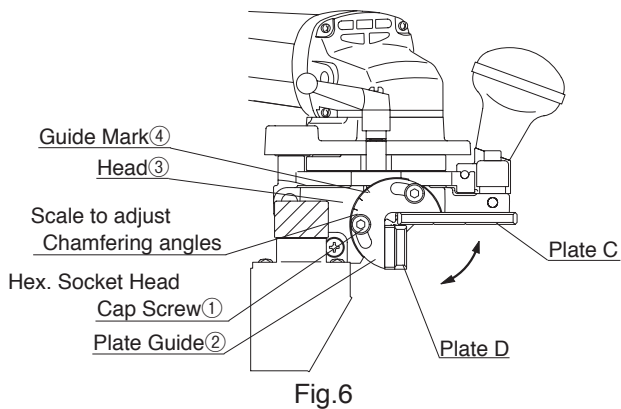

Fig.7

Chamfering Angle	Stainless Steel(mm)			Mild Steel(mm)		
	A	B	C	A	B	C
45°	3	3	4.2	7	7	9.9
30°	2.2	3.8	4.4	3.8	6.6	7.6
15°	1	3.8	3.9	1.5	5.6	5.8

Table.1

5-5. Before Cutting

- (1) When you start to work from the corner as shown in Fig.8, cut off the corner first with grinder etc., then start.

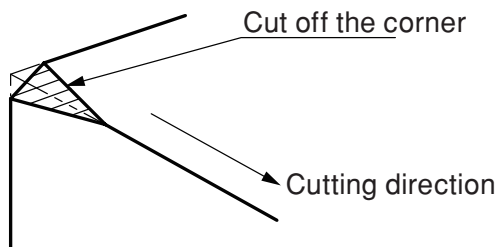

Fig.8

- (2) Before start chamfering, make sure that the Switch is set on and the Indexable Insert is rotating. Then, apply the tool to the workpieces. The Indexable Inserts may be damaged if the Switch is set on after Indexable Inserts are pressed on the workpieces or they may also be damaged if they are pressed to the workpieces abruptly.
- (3) The workpieces should be fixed as much as possible while working.

5-6. Feeding Speed

Be sure you should avoid quick feeding or heavy shock. Please refer to Table.2.

Stainless Steel	3cm/sec
Mild Steel	2cm/sec

Table.2

5-7. How To Operation

⚠ WARNING

- Be sure to turn the switch OFF and remove the power plug from power supply whenever adjusting chamfering levels.
 - The workpieces should be fixed as much as possible while working.
- (1) Select the chamfering level.
 - (2) Make sure that the Switch is set at "OFF" position and connect the power plug to the power supply.
 - (3) Hold the Housing up. Start the tool.
 - (4) Hold the Housing and Knob firmly. Apply the tool on to the workpiece along with the direction (shown on the Plate C) carefully.

In case of chamfering stainless steel, chamfer deep to the desired chamfering level by one span of operation. Repeat of chamfering makes the life of Indexable Insert shorter.

5-8. Radius Chamfering

- By using radius chamfering Indexable Inserts, radius chamfering job can be done.
 - Radius chamfering Indexable Insert is an optional accessory.
- (1) Select the radius chamfering.
 - (2) Make sure that the Switch is set at "OFF" position and connect the power plug to the power supply.
 - (3) Hold the Housing up. Start the tool.
 - (4) Hold the Housing and Knob firmly. Apply the tool on to the workpiece along with the direction (shown on the Plate C) carefully.

※On Tangential Line Cutting

Because of the constructional reason, it is possible to make a radius tangential line cutting on the side facing the Plate D by adjusting the Head, but impossible on the upper side facing the Plate C. For making a radius tangential line cutting on the upper side, conduct in a following manner.

- (1) Place the tool on workpiece with Plate C on upper surface of workpiece and Plate D on side surface, as indicated in Fig.9. Then, turn the Eccentric Ring to adjust the Indexable Inserts to cut properly side surface, and conduct the first cut. (see Fig.10)
- (2) Next, placing Plate C on side surface and Plate D on upper surface, conduct the second cut.
- (3) In this case, slight seam may be left in center of chamfered surface. (Fig.11)

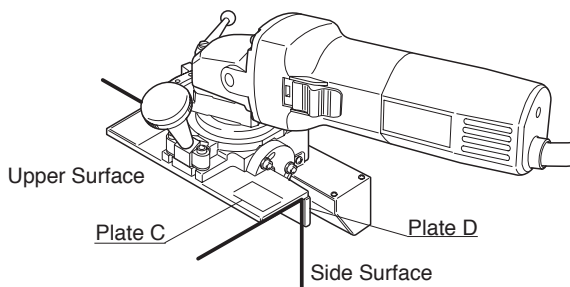

Fig.9

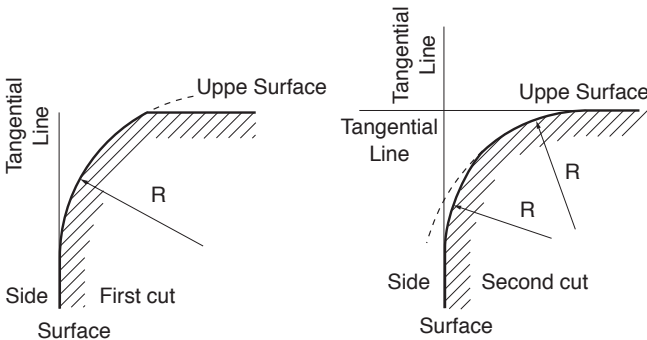

Fig.10

Fig.11

5-9. How To operation the Dust Box

⚠ WARNING

- Be sure to turn the switch OFF and remove the power plug from power supply whenever setting up the tool.
- The Dust Box is much heated right after the operation. Always wear gloves in handling the Dust Box.

⚠ CAUTION

- Frequently throw away the chips in the dust box before pilling up. If the tool is operated with the

dust box filled with the chips, it badly affects finishing surfaces shorten the life of Indexable Insert.

Hold the motor firmly, and throw away the chips by opening the lid. (Fig.12)

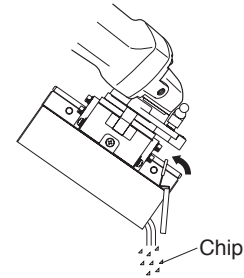

Fig.12

5-10. How To Chamfer Outer Diameter

⚠ WARNING

- Be sure to turn the switch OFF and remove the power plug from power supply whenever the accessories are attached or removed.

The tool can be used on the workpieces at the minimum diameter of 300mm by adjusting dimension A of both Hex. Socket Set Screws (8×25 special) ① in either direction. (Fig.13)

Remember that this operation requires the workpieces of at least 12mm length. (Fig.14)

- (1) In the case of constant R (Circle), install two Hex. Socket Set Screws (8×25 special) ① on Plate D and tighten with Hex. Nuts. Make sure that the dimension A of the left and the right screws are equal.

Chamfering on an outer diameter of O.D. 200mm – O.D. 300mm can be done by placing the Hex. Nut on the other side of Plate D. (Fig.13, 14)

- (2) In the case of variable R (Oval), remove one of the two Hex. Socket Set Screws (8×25 special) ①.

Remember that chamfering level changes depending on the radii in this case.

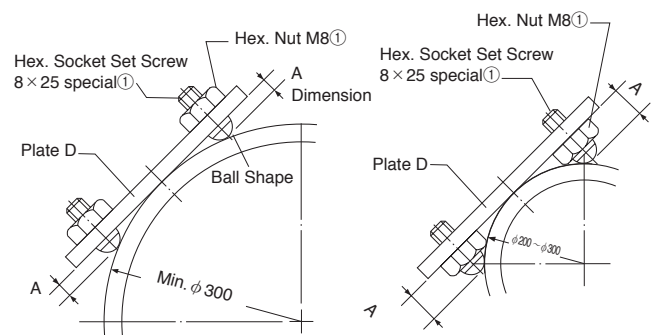

Fig.13

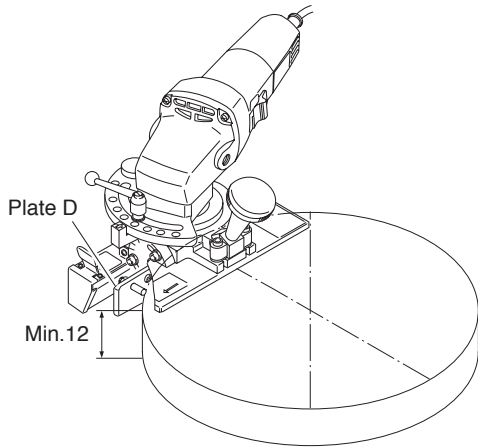

Fig.14

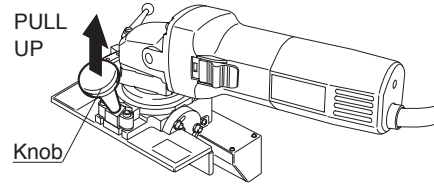

Fig.15

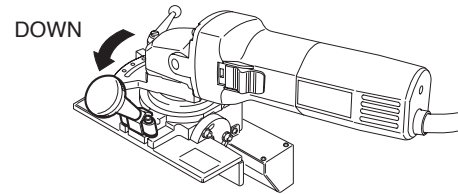

Fig.16

6. HOW TO REPLACE INDEXABLE INSERT

! WARNING

- Be sure to turn the switch OFF and remove the power plug from power supply whenever replacing Indexable Insert.
- The Indexable Insert and the Holder are much heated right after the operation. Always wear gloves in handling the Indexable Insert and the Holder.

- (1) Lay down the Knob with it pulled up. (Fig.15, 16)
- (2) Open the Lock Plate with the Knob laid down. (Fig.17)
- (3) Remove the Indexable Insert Set Screw using the Spanner T-15D attached to take off the Indexable Insert. (Fig.17)
- (4) Mount a new Indexable Insert (including use of reverse surface) paying attention to the direction of the Indexable Insert. (Fig.17)
- (5) Close the Lock Plate with the Knob laid down and lay the Knob aside to lock it. (Fig.18)

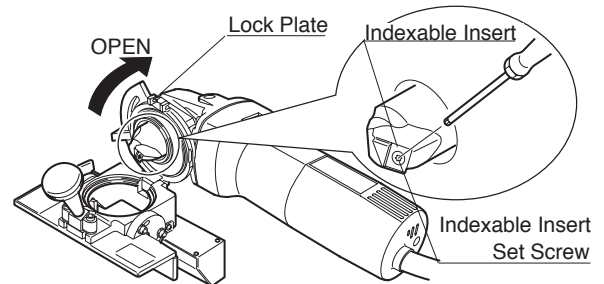

Fig.17

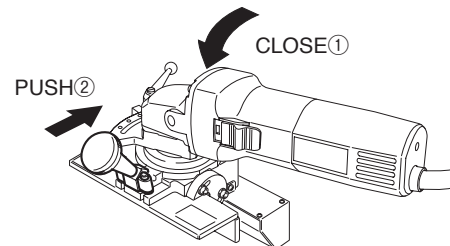

Fig.18

7. MAINTENANCE AND INSPECTION

! WARNING

- Be sure to turn the switch OFF and remove the power plug from power supply during maintenance and inspection.
- Perform periodic inspection to check for loosening of the attachment screws for each part. Retighten loose screws as required.

7-1. Replacing the Carbon Brushes

- After replacing the carbon brushes, always run the unit for at least 10 minutes under no load conditions.

Periodically check for wear on the Carbon Brushes, because as rectification deteriorates the likelihood

of a failure brush reaches around 5mm, follow the procedure below to replace the brush with new ones.

● **Because a cut-off brush is used, when it is worn electricity is automatically cut-off. If this happens, replace the carbon brush according to the following procedure.**

- (1) Loosen the Pan Head Tapping Screw and remove the Cover. (Fig.19)
- (2) Lift the spiral Spring, remove the Carbon Brush and replace it with the new Carbon Brush. (Fig.20)
- (3) Check that the cable is correctly connected.
- (4) Attach the Cover and securely tighten the Pan Head Tapping Screw. Be sure that the Tapping Screw is correctly threaded; do not attempt to tighten if the screw is cross-threaded.

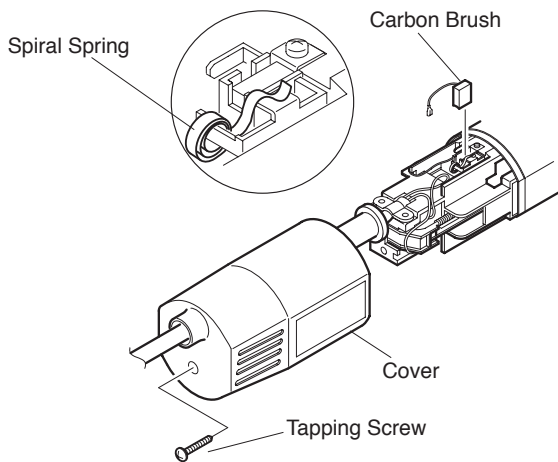

Fig.19

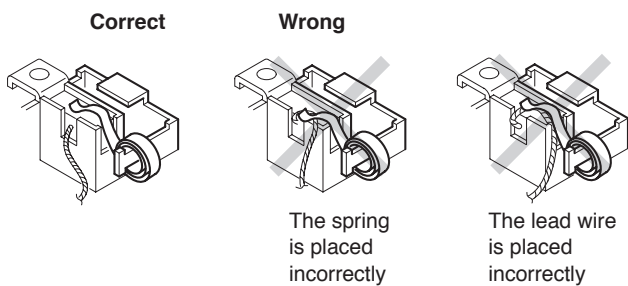

Fig.20

8. CONDITION FOR USE

Burn-out chips suggest that either the feed speed is too slow or the Indexable Insert has worn-out. Change the cutting conditions or check the conditions of the Indexable Insert.

9. ORDERING SERVICE PARTS

For further operational and handling information or for replacement of parts and components, contact the company from whom you purchased the tool or an authorized dealer.

In ordering parts and components give each part number, part name and quantity required.

Use only NITTO genuine parts.

10. OPTIONAL PARTS

Part No.	Description	Qty
TB01159	Indexable Insert with Hole 12.7	10pcs
TB01791	Indexable Insert 12.7 sq. R2	10pcs
TB01651	Indexable Insert 12.7 sq. R3	10pcs
TB01790	Indexable Insert 12.7 sq. R4	10pcs
TB02539	Attachment for Small Dia. Pipe ※	1set

※ For Steel Pipe Out Dia. 80mm – 200mm

11. EXPLODED DIAGRAM : EMB-0307C

WARNING

This diagram is for your reference only. Do not attempt to service or repair the Tool. Do not take the Tool apart. Contact an authorized Nitto dealer for all service and repair of the Tool. Improper service and repair can cause accidents and severe injuries. Never attempt to modify the Tool. Never attempt service or repair the Tool yourself.

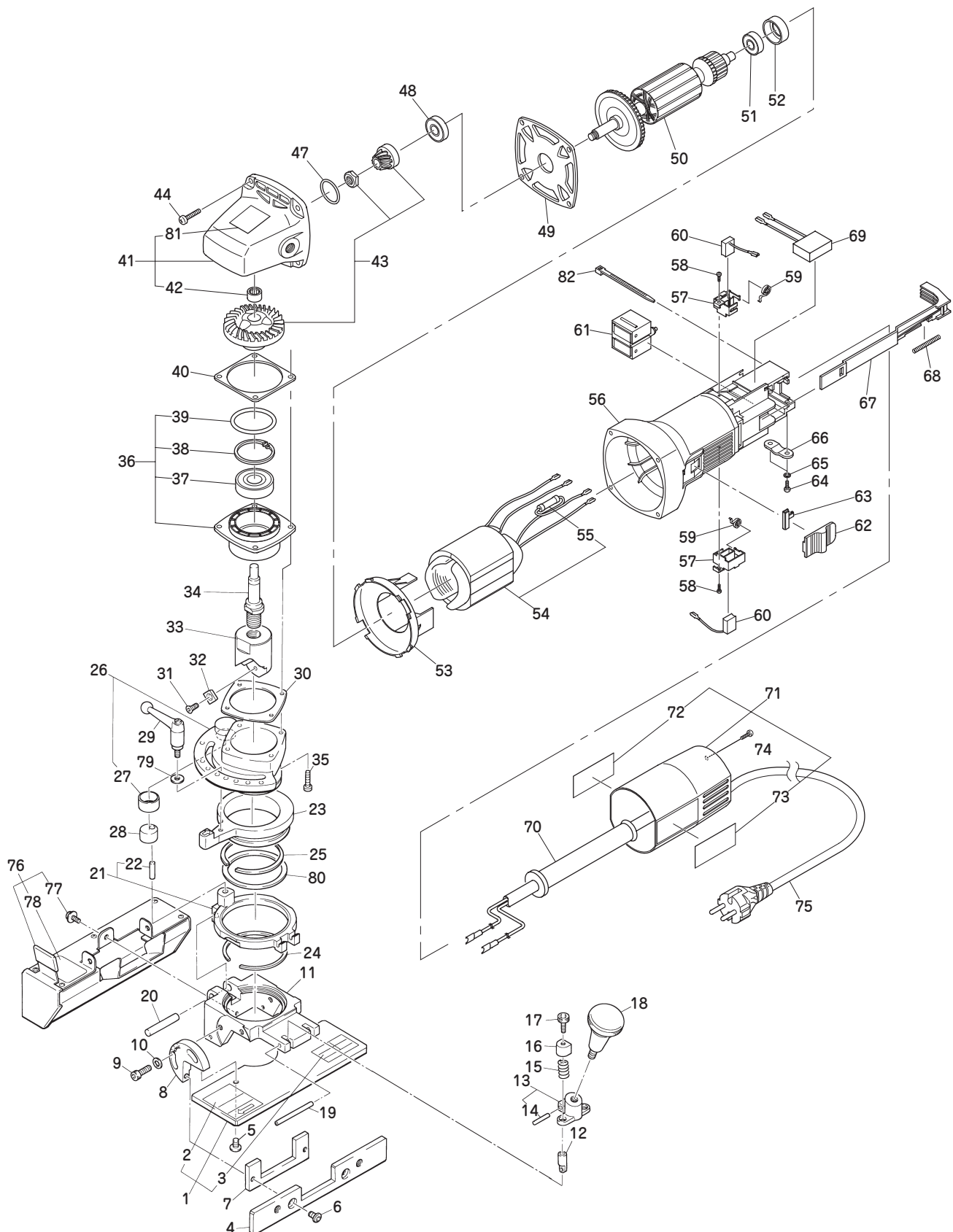

The part numbers with () are included in the Ass'y parts written above them.

No.	Part No.	Description	Qty	Price
1	TB02632	Plate C Ass'y	1set	
2	(TP16975)	Label A (Caution)	1	
3	(TQ01684)	Label B (Chamfering level)	1	
4	TQ03415	Plate D	1	
5	TQ00211	Hex. Socket Head Screw 5 x 8	2	
6	TQ00214	Hex. Socket Head Screw 5 x 12	2	
7	TQ04308	Plate Supporter	1	
8	TP18065	Plate Guide	2	
9	TP02862	Hex. Socket Head Cap Screw 5 x 15	4	
10	TP02152	Plain Washer M5	4	
11	TQ04301	Head	1	
12	TQ04305	Shaft	2	
13	TB03291	Lock Block A Ass'y	1set	
14	(TQ04306)	Parallel pin A4 x 25	1	
15	TQ10807	Spring 1.1 x 10.5 x 15	2	
16	TQ04303	Cover	2	
17	TP00021	Hex. Socket Head Cap Screw 5 x 10	2	
18	TA93017	Knob Ass'y	1set	
19	TQ04534	Spring Pin 5 x 50 AW	1	
20	TQ04300	Parallel Pin A8 x 35	1	
21	TB03290	Lock Plate Ass'y	1set	
22	TQ04298	Parallel Pin A6 x 20	1	
23	TQ04296	Eccentric Ring	1	
24	TQ04310	Concentric Snap Ring WR-65	1	
25	TP18056	Concentric Snap Ring WR-52	1	
26	TB03392	Adapter Ass'y	1set	
27	(TQ04442)	Bushing LFB-1810	1	
28	TQ04297	Eccentric Top	1	
29	TQ04294	Clamp Lever KR5 x 15	1	
30	TQ04328 TQ04329 TQ04330 TQ04331 TQ04332	Spacer t0.05 (for adjustment) Spacer t0.1 (for adjustment) Spacer t0.2 (for adjustment) Spacer t0.3 (for adjustment) Spacer t0.5 (for adjustment)		
31	TQ01629	Indexable Insert Set Screw 4 x 7	1	
32	TB01159	Indexable Insert with Hole 12.7 (10pcs. / Set)	1set	
33	TQ03412	Holder	1	
34	TQ13208	Spindle	1	
35	TQ10600	Hex. Socket Head Cap Screw 4 x 18	4	
36	TB08179	Bearing Case Ass'y	1set	
37	(TP16791)	Ball Bearing 6201LU / 2A	1	
38	(TQ11713)	Concentric Snap Ring IRTW-32	1	
39	(TQ01578)	O-ring 46 x 48 x 1	1	
40	TQ03822 TQ03823 TQ03824 TQ03825	Spacer For Bearing Case 0.1mm Spacer For Bearing Case 0.15mm Spacer For Bearing Case 0.2mm Spacer For Bearing Case 0.3mm		
41	TB09507	Gear Case A Ass'y	1set	
42	(TP16788)	Needle Bearing HK0808	1	
81	(TQ14198)	Label Caution		
43	TB08530	Gear Ass'y	1set	
44	TQ13287	Hexalobular Internal Pan Head Tapping Screw 4 x 25	4	
47	TQ10280	O-Ring S-22	1	

No.	Part No.	Description	Qty	Price
48	TQ14781	Ball Bearing 608-2RSL	1	
49	TQ13203	Bearing Plate	1	
50	TB09800	Armature Ass'y 115V	1set	
	TB09803	Armature Ass'y 230V	1set	
51	TQ14782	Ball Bearing 607-2RSL	1	
52	TQ13190	Rubber Cap	1	
53	TQ13202	Shroud	1	
54	TB09801	Stator Ass'y 115V	1set	
	TB09804	Stator Ass'y 230V	1set	
55	TB09408	Fuse Ass'y 100V	1set	
	TB09826	Fuse Ass'y 230V	1set	
56	TQ13192	Motor Case	1	
57	TB0911	Brush Holder Ass'y	2set	
58	LQ00621	Pan Head Tapping Screw 3 x 8	2	
59	TQ13195	Spiral Spring	2	
60	TB09041	Carbon Brush Ass'y	1set	
61	TB9409	Switch Ass'y	1set	
62	TQ13199	Slide Switch	1	
63	TQ13924	Switch Stopper	1	
64	TQ13810	Pan Head Tapping Screw 4 x 12	2	
65	TP04234	Spring Washer M4	2	
66	TQ10670	Cord Stopper	1	
67	TQ13200	Switch bar	1	
68	TQ13201	Switch Spring	1	
69	TB09375	Condenser Ass'y	1set	
70	TQ10667	Cord Armor	1	
71	TB09802	Rear Cover Ass'y 115V	1set	
72	(TQ14394)	Label Warning 115V	1	
73	(TQ14393)	Label Model Number 115V	1	
71	TB09805	Rear Cover Ass'y 230V	1set	
72	(TQ14455)	Label Warning 230V	1	
73	(TQ14454)	Label Model Number 230V	1	
74	TQ13288	Pan Head Tapping Screw 4 x 10	1	
75	TB09774	Cabtyre Cord Ass'y	1set	
76	TB03292	Dust Box Ass'y	1set	
77	(TQ04475)	Pan Head Screw 5 x 10	3	
78	(TQ12819)	Label Caution Dust Box	1	
79	TQ04642	Plain Washer M5 12 x 5.5 x 0.8	1	
80	TQ04775 TQ04776 TQ04777	Spacer t0.1 (for Lock Plate) Spacer t0.2 (for Lock Plate) Spacer t0.05 (for Lock Plate)		
82	TQ14603	Plastic Tie T18R-HS	1	

Accessories

No.	Part No.	Description	Qty	Price
		Indexeble Insert with Hole 12.7	1	
	TQ01629	Indexeble Insert Set Screw 4 x 7	1	
	TB09041	Carbon Brush Ass'y	1set	
	TP01939	Hex. Socket Screw Key 4	1	
	TQ01683	Spanner T-15D	1	
	TP08584	Hex. Nut M8	2	
	TP17133	Hex. SocketSet Screw 8 x 25	2	
	TQ14395	Instruction Manual	1	
	TQ14396	Declaration of Conformity	1	



Overseas Affiliates / Offices

NITTO KOHKI U.S.A., INC.

46 Chancellor Drive, Roselle, Illinois 60172, U.S.A.
For Cuplas
Tel : +1-630-924-5959 Fax : +1-630-924-1174
For Machine Tools
Tel : +1-630-924-9393 Fax : +1-630-924-0303
www.nittokohki.com

NITTO KOHKI EUROPE GMBH

Gottlieb-Daimler-Str. 10, 71144 Steinenbronn, Germany
Tel : +49-7157-989555-0 Fax : +49-7157-989555-40
www.nitto-kohki.eu/

NITTO KOHKI EUROPE GMBH UK Branch

Unit A5, Langham Park Industrial Estate, Maple Road,
Castle Donington, Derbyshire DE74 2UT, United Kingdom
Tel : +44-1332-653800 Fax : +44-1332-987273
www.nitto-kohki.eu/

NITTO KOHKI AUSTRALIA PTY LTD

77 Brandl Street, Eight Mile Plains, Queensland 4113, Australia
Tel : +61-7-3340-4600 Fax : +61-73340-4640
www.nitto-australia.com.au

NITTO KOHKI (SHANGHAI) CO., LTD.

Room1506, Suite C, Orient International Plaza,
No.85 Loushanguan Road, Shanghai 200336, China
Tel : +86-21-6415-3935 Fax : +86-21-6472-6957
www.nitto-kohki.cn

NITTO KOHKI (SHANGHAI) CO., LTD. Shenzhen Branch

2005C Shenzhen ICC Tower, Fuhuasanlu 168,
Futian District, Shenzhen, Guangdong 518048, China
Tel : +86-755-8375-2185 Fax : +86-755-8375-2187
www.nitto-kohki.cn

NITTO KOHKI CO., LTD. Singapore Branch

10 Ubi Crescent #01-62, Ubi Techpark Lobby D, Singapore 408564
Tel : +65-6227-5360 Fax : +65-6227-0192
www.nitto-kohki.co.jp/e/nksb/index.html

NITTO KOHKI CO., LTD. Bangkok Representative Office

M&A Business Center, Q-House Convent Bldg.,
38 Convent Rd., Silom, Bangrak, Bangkok 10500, Thailand
Tel : +66-2632-0307 Fax : +66-2632-0308
www.nittobkk.com

NITTO KOHKI CO., LTD. India Liaison Office

3rd Floor, Building No.9-A DLF Cyber City, Phase-III,
Gurgaon, Haryana 122002, India
Tel : +91-124-454-5031 Fax : +65-6227-0192

NITTO KOHKI CO., LTD. Mexico Representative Office

OF1109 Torre Corporativo 1 Piso 11 Central Park Armando Birlain Shaffler
#2001 Col Centro Sur, Queretaro, Qro, C.P. 76090, Mexico
Tel : +52-442-290-1234